

Rev No	Alteration	Date	Checked	Approved
01	Drawing approved	6. 7. 2016	sksm	PDM

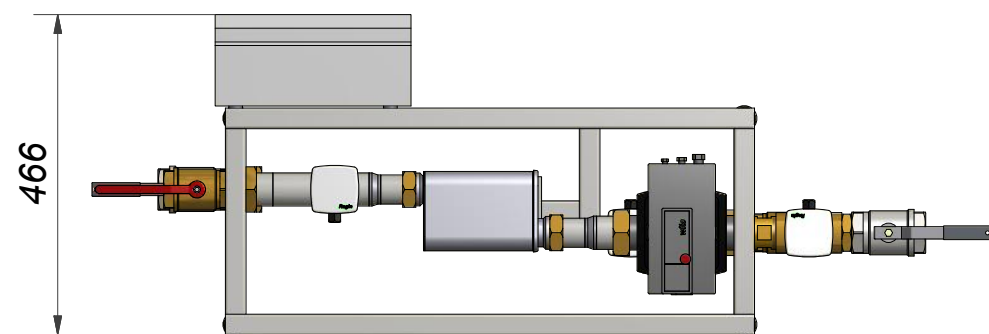

10	1	Cabinet	-	Rutab CT24NS 375x285x136
9	2	Threaded bar	-	Threaded bar M8 L50
8	2	Threaded bar	-	Threaded bar M8 L150
7	4	Pipe holder DN65 M8	-	Pipe holder DN65 M8, 3809384
6	1	Frame PCU	Swep	KA001949
5	1	Heat exchanger	Swep	B28Hx70/1P-SC-S 2x G1½"/2x G1½"
4	1	KA001954	Swep	KA001954
3	1	KA001953	Swep	KA001953
2	1	KA001952	Swep	KA001952
1	1	KA001951	Swep	KA001951

Item	QTY	Description	Vendor	Drawing / Article
Drawn	Checked	Approved	Created Date	General geometrical tolerancing ISO 2768:
skmtm	PDM	PDM	2016-01-05	General surface finish R_a
				Scale
				-
				Paper size
				A3

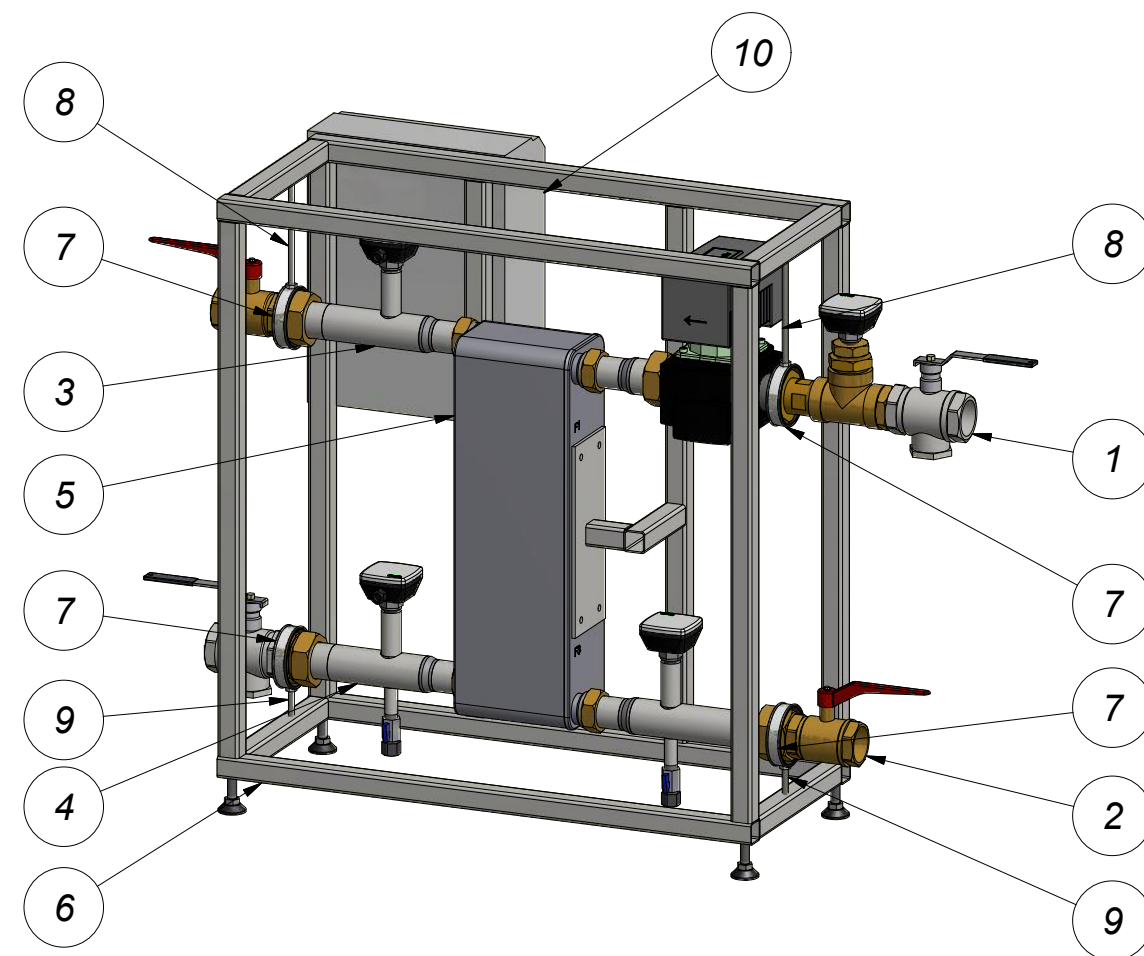
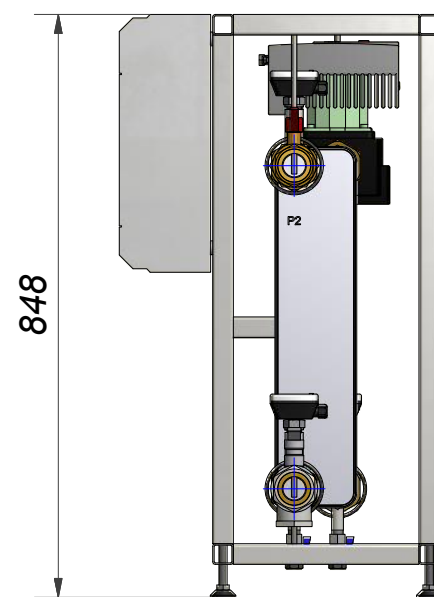
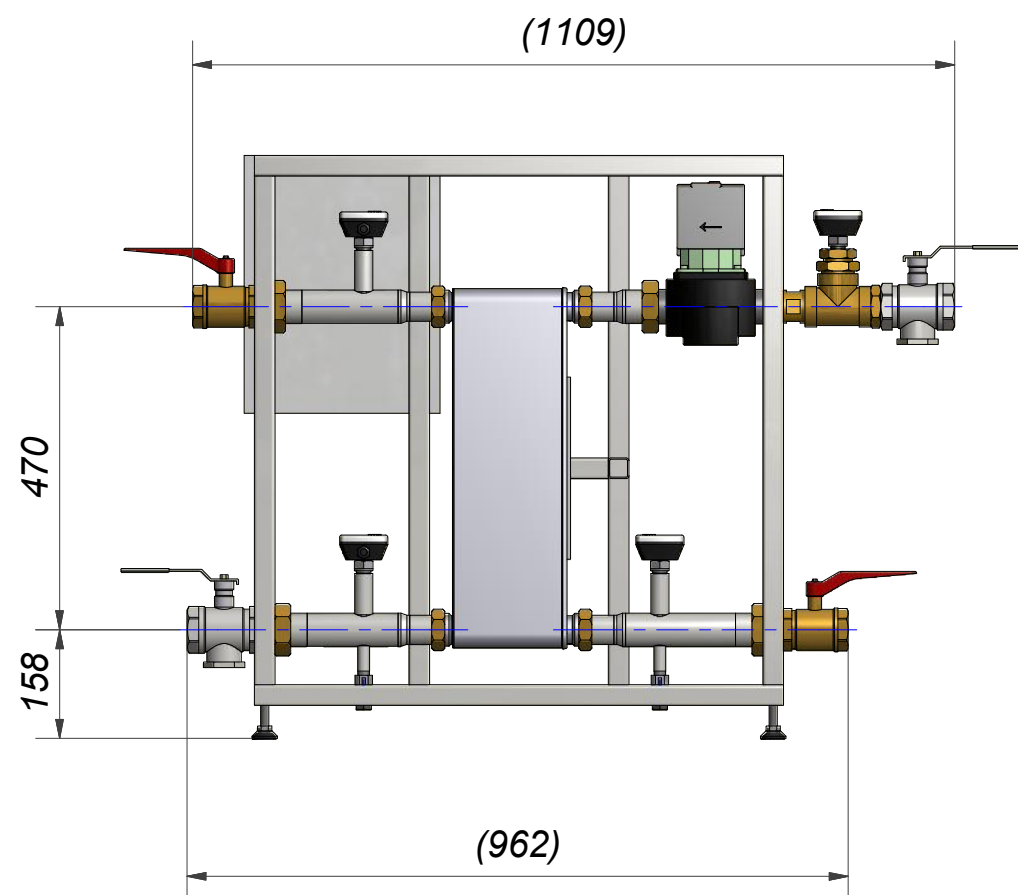

Title				
Bosch PCS 25 kW - Main assembly				
Article number	Design Type	Drawing number	Revision	Sheet
FA	FA	KA001950	01	1 (1)

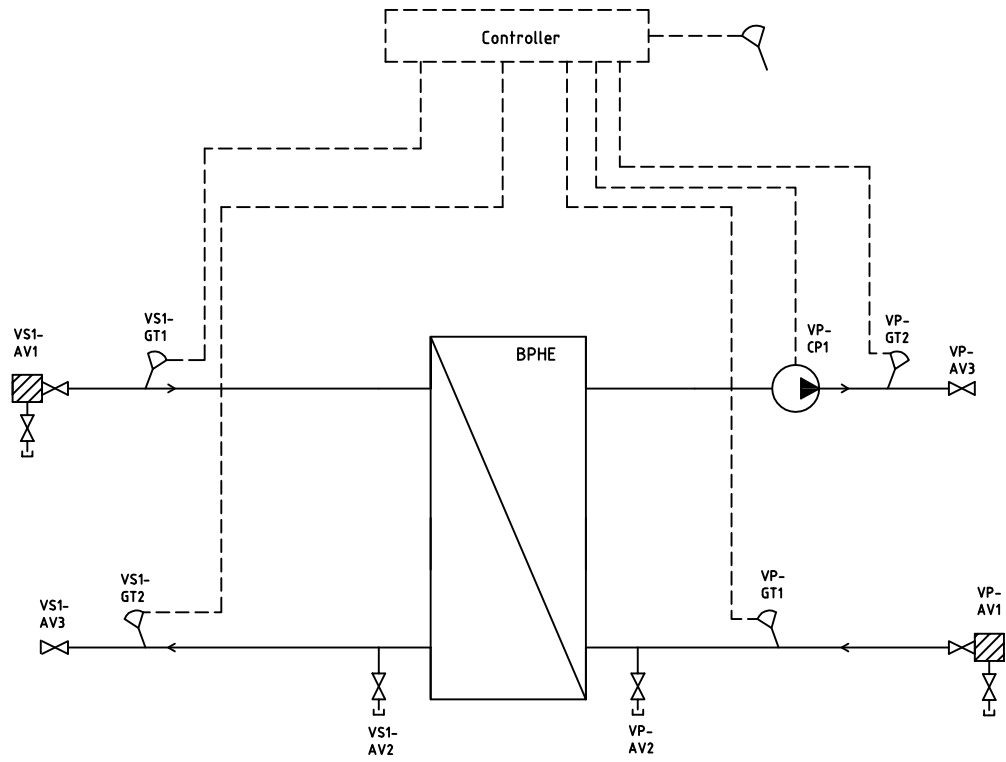

© Company Confidential, Property Of SWEP International AB

Drawn SKSM	Checked LAEW	Approved LAEW	Date 2016-05-11	General geometrical tolerancing ISO 2768: -	General surface finish R_a -		Scale 1:1
			Title Flow chart Bosch PCU 25kW				
			Article number -	Drawing number KB000331	Revision 2	Sheet 1(1)	